

Schaevitz® A545 Multi Series

DC-Operated,
Bi-axial & Tri-axial Linear Accelerometer

Clearly the first choice for precision

Features

- Ranges $\pm 2g$ to $\pm 500g$
- Integral overload protection
- Critical damping ratio 0.7 nominal with essentially zero temperature coefficient
- Integral temperature compensation
- DC input - DC output
- Suitable for DC and AC acceleration applications
- Available in 2 and 3 axis versions

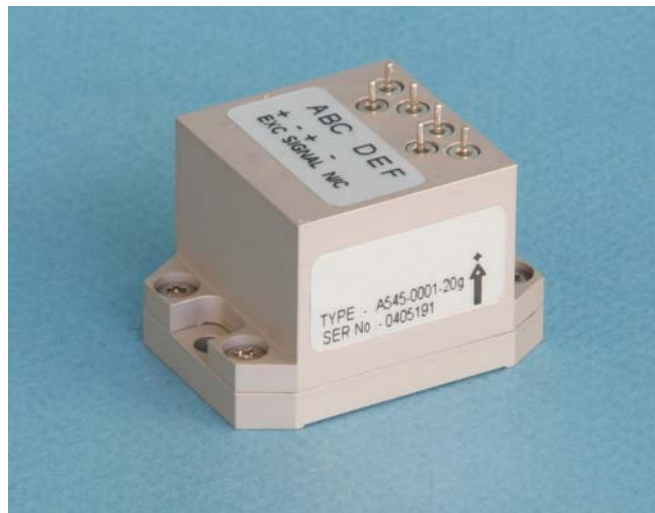

Introduction

The Sherborne Sensors' A545 range of multi-axis accelerometers measure vector acceleration in three mutually perpendicular planes with high accuracy and incorporate piezo-resistive strain gauge bridge sensors incorporating air damping. Unlike fluid damped devices, the air damping employed is essentially independent of temperature. The transducer also incorporates positive mechanical stops conferring excellent shock resistance.

The accelerometer is compensated for the effects of temperature on both sensitivity and zero.

Typical applications include biomechanical investigations, data acquisition systems, crash test, impact, shock and vibration analysis.

Designed for operation from a DC power source, the A545 is packaged in a robust aluminium alloy housing with solder pin connections. The accelerometer has a wide-range useable frequency response from DC to several kHz.

In addition to the instruments offered in this bulletin Sherborne Sensors design and develop accelerometers for specific applications. These custom designed units can be manufactured and tested to conform to specific requirements and standards.

Schaevitz® A545 Multi Series

DC-Operated,
Bi-axial & Tri-axial Linear Accelerometer



General Specification

Input

Ranges ($\pm g$) 2; 5; 10; 20; 50; 100; 200; 500
 Excitation 5.00 \pm 0.01 Vdc. Regulated to 8ppm/V (Max)
 Input Current 5mA dc max per axis

Output at 25°C

Zero Offset $\leq \pm 2$ mV
 Nonlinearity $\leq \pm 0.5\%$ FRO
 Hysteresis $\leq 0.02\%$ FRO
 Resolution $\leq 0.0005\%$ FRO
 Cross Axis Sensitivity $\leq \pm 1\%$ FRO
 Noise Output 1 μ V (p-p) max
 Damping Ratio 0.7 (± 0.2) @ 25°C
 Output Impedance 2.5 to 6.5 k Ω

Environmental

Temp. Operating -40°C to +105°C
 Temp. Compensated 0°C to +50°C
 Temp. Storage -55°C to +130°C
 Thermal Sensitivity Shift $\leq \pm 0.02\%$ FRO/°C
 Thermal Zero Shift $\leq \pm 0.02\%$ FRO/°C
 Acceleration limit 400g for 2 to 10 g versions, 20 x range or 2000g, whichever is lower for other versions (any direction)
 Humidity/Immersion IP65
 Insulation Resistance ≥ 20 M Ω at 50V dc

Physical

Sensitive Axis Alignment See diagram
 Weight 40 grams max

Electrical Connections

Solder Pin Connections Pin A : + dc excitation
 Pin B : 0V dc excitation
 Pin C : - Signal 'X' axis
 Pin D : + Signal 'X' axis
 Pin E : - Signal 'Y' axis
 Pin F : + Signal 'Y' axis
 Pin G : - Signal 'Z' axis (option)
 Pin H : + Signal 'Z' axis (option)

Range (g)	Full Range Output (Min/Max) (mV)	Resonant Frequency (Hz)	Frequency Response (Hz $\pm 5\%$)
± 2	12/18	700	0 to 250
± 5	12/18	800	0 to 300
± 10	12/18	1000	0 to 400
± 20	12/18	1500	0 to 600
± 50	12/18	2000	0 to 1000
± 100	12/18	3000	0 to 1500
± 200	30/60	4000	0 to 2000
± 500	30/60	5000	0 to 2400

Note: The full range output is that obtained using 5volt excitation

DESIGNATION & ORDERING CODE

A545 - 000 - G

Series Number

- 2. Dual-axis (X & Y)
- 3. Tri-axis (X, Y & Z)

Range in g

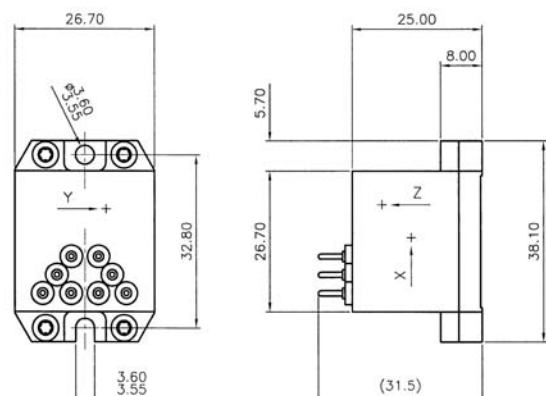

1 Ringway Centre, Edison Road, Basingstoke, Hampshire, RG21 6YH, United Kingdom
 Tel: +44 (0) 870 444 0728 Fax: +44 (0) 870 444 0729 Email: sales@sherbonesensors.com
 Website: www.sherbonesensors.com